

RACK ACCESSORIES

Combination lock with universal key for floor and server rack series



Description

ORCA Combination lock with universal key

How to use:

Handle at factory setting "000"

Opening with the key:

- Insert the key into lock - Turn the key 180 ° counter clockwise (pic. 2).
- Lift the handle and turn.
- To re-lock. turn the key 180 ° clockwise

Opening with combination lock:

- Dial in correct combination, factory set at "000".
- Turn wing knob 180 ° counter clockwise till the arrow points up "open lock icon".
- Lift the handle and turn.
- To re-lock, turn wing knob 180° clock-wise to lock and scramble the combination.

To change the combination:

- To change the combination the exiting code must be known.
- The keylock must be in the locked position "close lock icon".
- Dial in the exiting combination.
- Turn wing knob 180° + 15° counter clockwise (pic. 4).
- Enter the new combination. Turn wing knob 15 ° clockwise, the new combination is now set.
- Turn wing knob 180° clockwise to lock then scramble the combination.

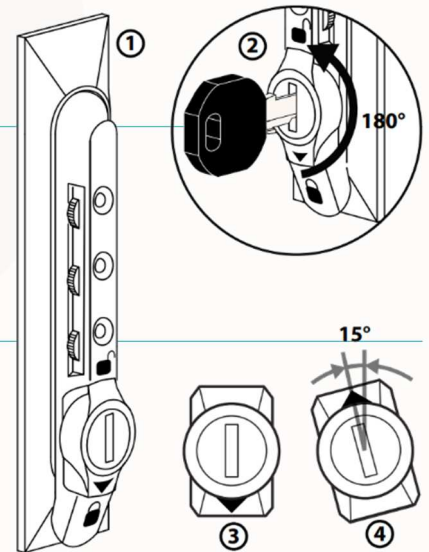

Ordering Information code:

OC-RAC-550505-01N ORCA – Combination lock with universal key for floor rack series

Specifications subject to change without prior notice - For more details please visit www.orca.it